

Diese Zeichnung darf ohne unsere Genehmigung weder vervielfältigt, noch dritten Personen zugänglich gemacht werden und bleibt unser Eigentum. Zuwiderhandlung ist strafbar.
 All rights strictly reserved. Reproduction or issue to third parties in any form whatever is not permitted without written authority from the proprietor. Violation is punishable.
 Gesamte und digital verteilte Zeichnungen benötigen zur Freigabe keine Unterschrift!
 Scanned and digitally distributed drawings do not need a signature for the release!
 Technische Änderungen vorbehalten!
 Technical modifications will be reserved.
 Verteiler distributor
 Empfänger receiver
 SDH
 SDW

ECO-FLEX M (RAST 5) Messerleiste in THT-Einlötltechnik für waagrechtes Stecken, Rastfenster unten, erhöhte Variante für Außenrastarm, mit Zapfen, mit versetztem Rastloch im Kontakt
 ECO-FLEX M (RAST 5) Tab connectors in THT soldering technology for horizontal connections, raised version, for locking feature outside at bottom, with pegs, with staggered locking feature at contact

Raster: / pitch: 5mm
 Identifikator: / identification: MSVV_9408-010_B_KF
 Blatt: / page: B

Fehlende Maße und Hinweise siehe separate Kundenzeichnung
 Missing dimensions and notes see separate customer drawing



STOCKO CONTACT GmbH & Co. KG

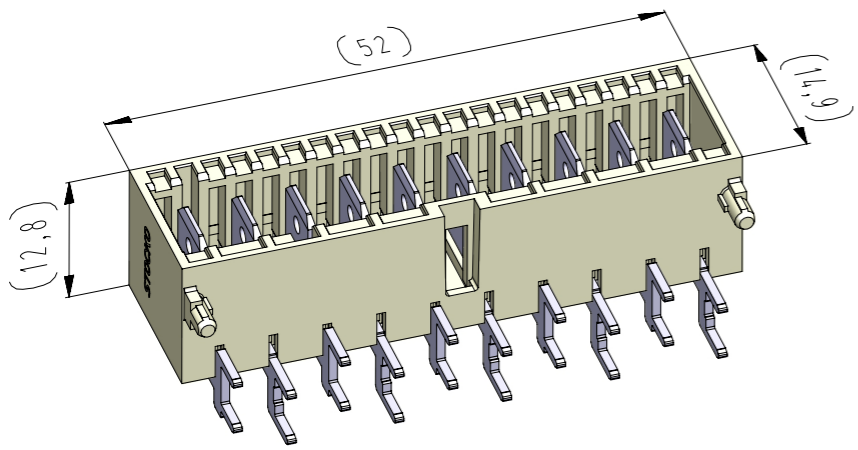

Lochbild (Bestückungsseite) / hole pattern (component side)

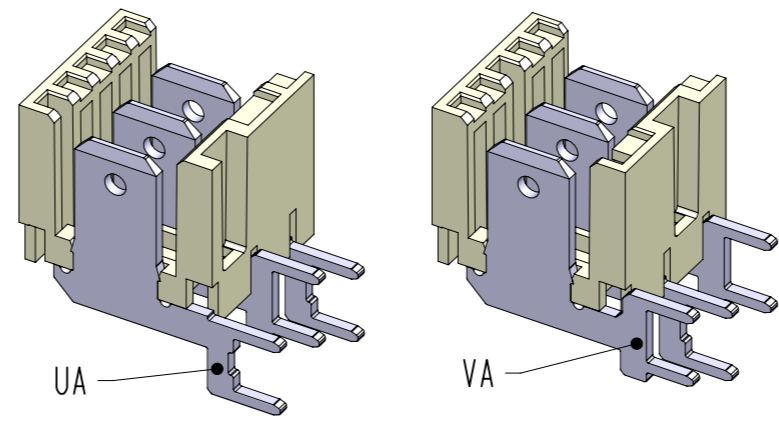
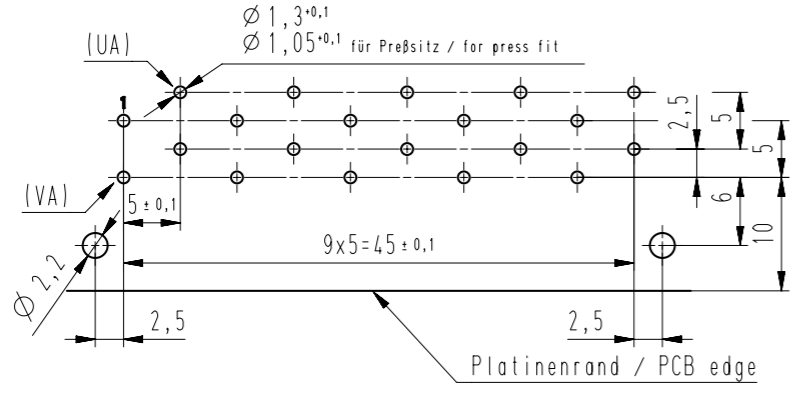

vereinfachte Darstellung einer möglichen Abart
 simplified representation of possible variation

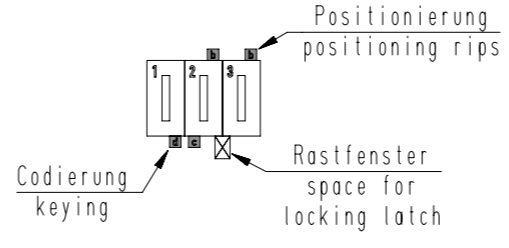

Beispiel Artikelbezeichnung:
 example part description:

MSVV 9408-010-W10-CCC-MMM-NN

- Farbmarkierung / colour marking
- Beschriftungscode / labeling code
- Material und Farbcode material and colour code
- Abart / variant
- Kontaktcode / contact code
- Polzahl / no. of poles
- Artikel-Nr. / part no.
- Verpackungscode / packing code
- Alpha-Teil der Artikelbezeichnung alpha part of the part description

| -VV- | |
|--------------------------------|----------------------------------|
| Verpackungscode / packing code | Bemerkung / remark |
| VV | |
| LO | lose, geschüttet / slack pouring |
| EM | Einzelmagazine / single magazine |

| -W- | | | |
|-----|--|---------------------|----------------------|
| W | Kontakt Artikel-Nr. / contact part no. | Material / material | Veredelung / plating |
| 0 | UA = RM 6147.051 P 0,8-6,3 | CuZn | Sn |
| 0 | VA = RM 6148.051 P 0,8-6,3 | | |

| Artikelbezeichnung part description | Anzahl der Kontakte number of contacts | Bestückung / loading | | | | | | | | | | Codierungsvariante siehe Tabelle see chart MH 8420-010 | Rastfenster zwischen den Kammern space for locking latch between chambers Bemerkung / remark | | | | |
|--|---|----------------------|----|----|----|----|----|----|----|----|----|---|---|---|---|---|---|
| | | 1 | 2 | 3 | 4 | 5 | 6 | 7 | 8 | 9 | 10 | | | | | | |
| MSVV 9408-010-510-CCC-MMM-NN | 10 | VA | UA | VA | UA | VA | UA | VA | UA | VA | UA | 10 | X | X | X | X | X |
| MSVV 9408-010-576-CCC-MMM-NN | 10 | VA | UA | VA | UA | VA | UA | VA | UA | VA | UA | 76 | X | X | X | X | X |
| | | | | | | | | | | | | | | | | | |
| | | | | | | | | | | | | | | | | | |
| | | | | | | | | | | | | | | | | | |
| | | | | | | | | | | | | | | | | | |
| | | | | | | | | | | | | | | | | | |
| | | | | | | | | | | | | | | | | | |
| | | | | | | | | | | | | | | | | | |
| | | | | | | | | | | | | | | | | | |
| | | | | | | | | | | | | | | | | | |
| | | | | | | | | | | | | | | | | | |
| | | | | | | | | | | | | | | | | | |
| | | | | | | | | | | | | | | | | | |
| | | | | | | | | | | | | | | | | | |
| | | | | | | | | | | | | | | | | | |
| | | | | | | | | | | | | | | | | | |
| | | | | | | | | | | | | | | | | | |
| | | | | | | | | | | | | | | | | | |

| Artikelbezeichnung part description | Anzahl der Kontakte number of contacts | Bestückung / loading | | | | | | | | | | Codierungsvariante siehe Tabelle see chart MH 8420-010 | Rastfenster zwischen den Kammern space for locking latch between chambers Bemerkung / remark | | | | |
|--|---|----------------------|---|---|---|---|---|---|---|---|----|---|---|--|--|--|--|
| | | 1 | 2 | 3 | 4 | 5 | 6 | 7 | 8 | 9 | 10 | | | | | | |
| | | | | | | | | | | | | | | | | | |
| | | | | | | | | | | | | | | | | | |
| | | | | | | | | | | | | | | | | | |
| | | | | | | | | | | | | | | | | | |
| | | | | | | | | | | | | | | | | | |
| | | | | | | | | | | | | | | | | | |
| | | | | | | | | | | | | | | | | | |
| | | | | | | | | | | | | | | | | | |
| | | | | | | | | | | | | | | | | | |
| | | | | | | | | | | | | | | | | | |
| | | | | | | | | | | | | | | | | | |
| | | | | | | | | | | | | | | | | | |
| | | | | | | | | | | | | | | | | | |
| | | | | | | | | | | | | | | | | | |
| | | | | | | | | | | | | | | | | | |
| | | | | | | | | | | | | | | | | | |
| | | | | | | | | | | | | | | | | | |
| | | | | | | | | | | | | | | | | | |

| -CCC- | |
|---|-----------------------------|
| Material und Farbcode material and colour code | |
| Materialinformation siehe Kundenzeichnung material data see customer drawing | |
| Leergehäuse / housing: MH 9406-... | |
| PA66-GF25 | |
| Code-Nr. code no. | Farbe colour |
| 118 | zinkgelb / zinc yellow |
| 121 | ropsgelb / rope yellow |
| 314 | altrosa / antique pink |
| 512 | lichtblau / light blue |
| 518 | türkisblau / turquoise blue |
| 605 | moosgrün / moos green |
| 701 | silbergrau / silver grey |
| 905 | schwarz / black |
| 960 | natur / nature |

| -MMM- | | |
|---|--------------------|---------------------------------------|
| Beschriftungscode nach Kundenwunsch labeling code acc. to the customer | | |
| Code-Nr. code no. | siehe WN see WN | Farbe colour |
| 000 | ---- | ohne Beschriftung without labeling |
| X** | 30,80 | Standard / standard |

| -NN- | |
|--|----------------|
| Code-Nr. für Farbmarkierung siehe WN 30.83 code no. for colour marking see WN 30.83 | |
| Code-Nr. / code no. | Farbe / colour |
| 00 | ohne / without |

| 10 | Material WN 14.0634.01 mit Materialcode -960- hinzu | 04.03.22 | U0013643 |
|-------------------|--|-----------|-------------------------------|
| 9 | Material und Farbcode 627, 715, 721 ungültig und 121 hinzu | 11.09.20 | U0013643 |
| Index | Änderung / modification | | Name |
| | Datum date | Name name | Projektleiter project manager |
| erstellt prepared | 11.02.09 | U0013643 | D.M. |

MSVV 9408-010

Beachten Sie die allgemeinen Sicherheits- und Verarbeitungshinweise für Steckverbinder und Kontakte: <http://www.stocko.de/catalog/pdf/Sicherheitshinweise.pdf> Respect general safety and processing information for connectors and contacts: <http://www.stocko.de/catatalog/pdf/safety-information.pdf>